

FORGED STEEL
FITTINGS
& UNIONS





B
BONNEY FORGE

SALES CENTER/WAREHOUSE
14496 CROGHAN PIKE
P.O. BOX 330
MT. UNION, PA 17066
(814) 542-2545 • (800) 231-0655
(800) 345-7546 • FAX (814) 542-9977
www.bonneyforge.com
e-mail: bfsales@bonneyforge.com

Corporate Overview.....	2, 3
Condensed Description	4, 5
90° Elbow – Class 2000, 3000, 6000 & 9000	6
45° Elbow – Class 2000, 3000, 6000 & 9000	7
Tee – Class 2000, 3000, 6000 & 9000	8
Cross – Class 2000, 3000, 6000 & 9000.....	9
Lateral – Class 3000, 6000 & 9000.....	10
Street Elbow – Class 3000 & 6000.....	11
QuikLeg 90° – Class 3000 & 6000	12
Boss With Lip – Class 3000 & 6000.....	13
Socket Weld Couplings, Reducers and Caps – Class 3000, 6000 & 9000 ..	14
Threaded Couplings, Reducers and Caps – Class 3000 & 6000	15
Plugs & Bushings – Class 3000/6000	16
Socket Weld Reducer Inserts (MSS-SP-79) – Class 3000, 6000 & 9000 ..	17
SP-83 Union – Class 3000 & 6000.....	18
Rockwood Unions.....	19
Lug Nut Unions	20
Technical Data.....	21



Bonney Forge - The Company You Rely on For Forged Steel Fittings and Unions

Since 1967, one name has been synonymous with premier Forged Steel Fittings and Unions – Bonney Forge.

Our continued investment in new technology helps maintain a constant level of superior quality in our products, which is unparalleled in the industry. Some of this new technology includes, state-of-the-art machining centers, which reduce product variability while increasing product serviceability and laser marking machines, which increases our capability to provide part information even on the smallest of components.

Backing by the most comprehensive product line in the industry and an extensive inventory that makes all our products readily available, Bonney Forge is the number one resource for the power, oil, chemical, marine, and construction industries through-out the world.

Dependable, Durable, Uniform and Precise

Our unparalleled, integrated, state of the art manufacturing facility allows Bonney Forge to develop products at the highest volume, all of which define the Bonney Forge mission – consistent unyielding quality. The tight control we maintain over our manufacturing process has earned Bonney Forge ISO-9001 recognition. Additionally, products are inspected to the



strict requirements of ASME B16.11, MSS SP-79, and MSS SP-83.

Superior Corrosion Resistance

All carbon and low alloy steel fittings are zinc-phosphate coated for superior corrosion resistance. Stainless steel fittings are electropolished to remove free iron and to provide a high-quality finish. All of this is done to ensure our products have the highest degree of corrosion resistance.

All The Fittings You Need

Our fittings come in a variety of classes and material grades for any application. Socket Weld fittings are available in class 3000, 6000 and 9000. Threaded fittings are available in class 2000, 3000, and 6000.

Threaded couplings, reducers, unions, half couplings and caps are available in class 3000 and 6000. Socket Weld couplings, reducers, half couplings and reducer inserts are available in class 3000, 6000 and 9000.

Other specialty designed products are available upon request including the following:

- Reducing Tees
- Multiple end configurations
- Special length couplings
- We also consider customer specific drawings



The Best Value - Price, Quality, Service All The Time.

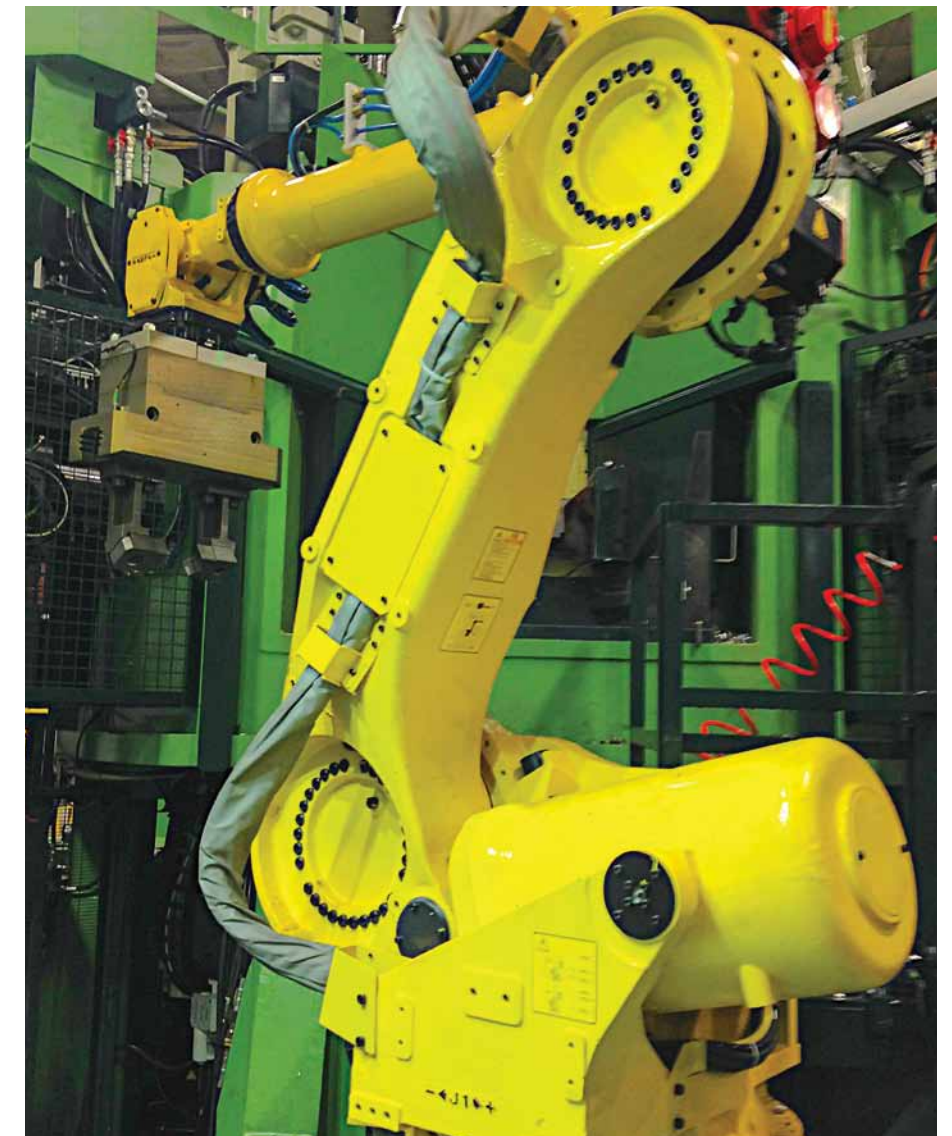

SOCKET WELD/THREADED FITTINGS

- Threaded - Available in Class 2000, 3000, & 6000
- Socket Weld - Available in Class 3000, 6000 & 9000

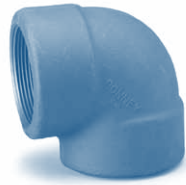

90° Elbow
Threaded
Class 2000 - 1/4" to 4"
Class 3000 - 1/8" to 4"
Class 6000 - 1/8" to 4"
Socket Weld
Class 3000 - 1/8" to 4"
Class 6000 - 1/8" to 4"
Class 9000 - 1/2" to 2"



45° Elbow
Threaded
Class 2000 - 1/4" to 4"
Class 3000 - 1/8" to 4"
Class 6000 - 1/8" to 4"
Socket Weld
Class 3000 - 1/8" to 4"
Class 6000 - 1/8" to 4"
Class 9000 - 1/2" to 2"



Tee
Threaded
Class 2000 - 1/4" to 4"
Class 3000 - 1/8" to 4"
Class 6000 - 1/8" to 4"
Socket Weld
Class 3000 - 1/8" to 4"
Class 6000 - 1/8" to 4"
Class 9000 - 1/2" to 2"



Cross
Threaded
Class 2000 - 1/4" to 4"
Class 3000 - 1/8" to 4"
Class 6000 - 1/8" to 4"
Socket Weld
Class 3000 - 1/8" to 4"
Class 6000 - 1/2" to 3"
Class 9000 - 1/2" to 2"



Lateral
Threaded
Class 3000 - 1/4" to 2"
Class 6000 - 1/2" to 1 1/2"
Socket Weld
Class 3000 - 3/8" to 2"
Class 6000 - 1/2" to 2"
Class 9000 - 1/2" to 1 1/2"



Street Elbow
Threaded
Class 3000 - 1/8" to 2"
Class 6000 - 1/8" to 1 1/2"

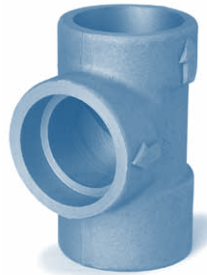

QuikLeg 90°
Threaded
Class 3000 - 1/2" to 2"
Class 6000 - 1/2" to 1 1/2"
Socket Weld
Class 3000 - 1/2" to 2"
Class 6000 - 3/4" to 2"

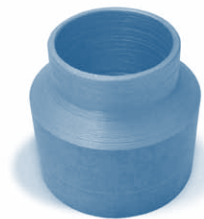

Boss w/Lip
Threaded
Class 3000 - 1/4" to 3"
Class 6000 - 1/8" to 3"
Socket Weld
Class 3000 - 1/4" to 3"
Class 6000 - 1/8" to 3"



Round Plug
1/8" to 4"



Hexagon Plug
1/8" to 4"



Square Plug
1/8" to 4"

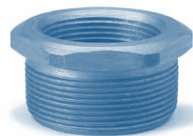

Hexagon Bushing
1/4" to 4"

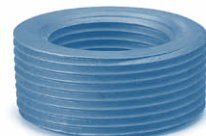

Flush Bushing
1/4" to 4"

Additional sizes available on request

COUPLINGS, REDUCERS & CAPS

Available in class 3000 and 6000.

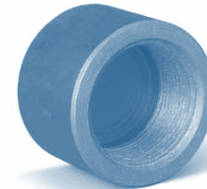

Pipe Cap
Threaded
Class 3000 - 1/8" to 4"
Class 6000 - 1/8" to 4"
Socket Weld
Class 3000 - 1/8" to 4"
Class 6000 - 1/8" to 4"

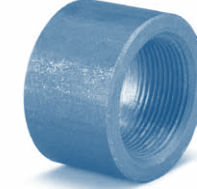

Half Coupling
Threaded
Class 3000 - 1/8" to 4"
Class 6000 - 1/8" to 4"
Socket Weld
Class 3000 - 1/8" to 4"
Class 6000 - 1/8" to 4"
Class 9000 - 1/2" to 2"



Coupling
Threaded
Class 3000 - 1/8" to 4"
Class 6000 - 1/8" to 4"
Socket Weld
Class 3000 - 1/8" to 4"
Class 6000 - 1/8" to 4"
Class 9000 - 1/2" to 2"

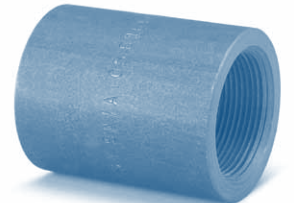

Reducer
Threaded
Class 3000 - 1/4" to 4"
Class 6000 - 1/4" to 4"
Socket Weld
Class 3000 - 1/4" to 4"
Class 6000 - 1/4" to 4"
Class 9000 - 1/2" to 2"

REDUCER INSERTS

Socket weld reducer inserts available in class 3000, 6000 and 9000. Inserts stocked in various materials. Consult factory for special applications.



Type 1
Nominal pipe sizes
from 1/4" x 1/8"
to 2" x 1 1/2"

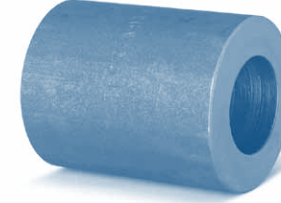

Type 2
Nominal pipe sizes
from 1/2" x 1/4"
to 2" x 1 1/4"

UNIONS

Bonney Forge MSS-SP-83 threaded and socket weld unions in class 3000 and 6000. Use Bonney Forge Rockwood Unions for the ultimate in operation and durability.

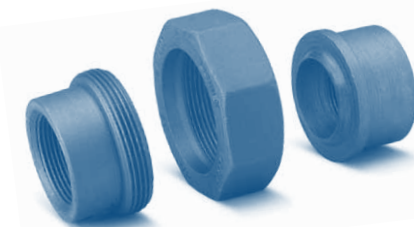

MSS-SP-83
Accommodates 1/8" to 3" pipe class 3000
and 1/4" to 2" pipe class 6000.

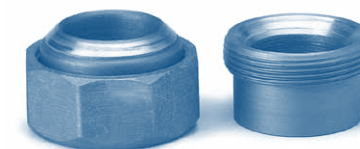

Rockwood
For use with 1/8" to 2" pipe. 1/8" to 2"
threaded connection. 1/4" to 2" socket
weld-stainless steel only.

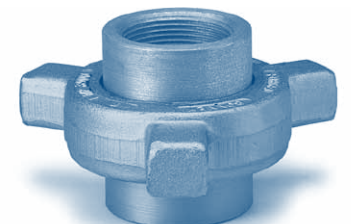

Lug Nut
3/8" to 4" class 3000 and 1/2" to 2"
class 6000 threaded & socket weld.

Additional sizes available on request

B[®] 90° ELBOW

BONNEY FORGE

CLASS 2000
CLASS 3000
CLASS 6000
CLASS 9000

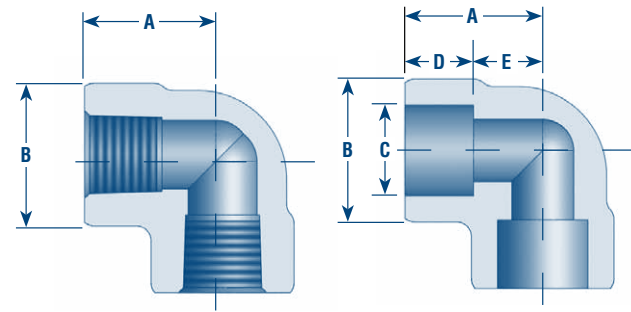

SPECIFICATIONS:
ASME B16.11
ASME B1.20.1 - (NPT)

Threaded

CLASS	DIMENSIONS	SIZES (INCHES)												
		1/8	1/4	3/8	1/2	3/4	1	1 1/4	1 1/2	2	2 1/2	3	4	
2000	A		7/8	31/32	1 1/8	1 5/16	1 1/2	1 3/4	2	2 3/8	3	3 3/8	4 3/16	
	B		29/32	1 1/16	1 5/16	1 9/16	1 27/32	2 7/32	2 1/2	3 1/32	3 5/8	4 5/16	5 3/4	
	WEIGHT		0.23	0.29	0.48	0.75	1.08	1.59	2.19	3.52	7.09	11.33	25.08	
3000	A		7/8	31/32	1 1/8	1 5/16	1 1/2	1 3/4	2	2 3/8	2 1/2	3 1/4	3 3/4	4 1/2
	B		29/32	1 1/16	1 5/16	1 9/16	1 27/32	2 7/32	2 1/2	3 1/32	3 11/32	4	4 3/4	6
	WEIGHT		0.27	0.35	0.58	0.97	1.42	2.29	2.77	5.43	5.87	11.03	17.50	33.20
6000	A		31/32	1 1/8	1 5/16	1 1/2	1 3/4	2	2 3/8	2 1/2	3 1/4	3 3/4	4 3/16	4 1/2
	B		1 1/16	1 5/16	1 9/16	1 27/32	2 7/32	2 1/2	3 1/32	3 11/32	4	4 3/4	5 3/4	6
	WEIGHT		0.37	0.65	1.05	1.64	2.69	3.62	6.13	7.84	14.40	22.95	37.12	33.42

Socket Weld

CLASS	DIMENSIONS	SIZES (INCHES)												
		1/8	1/4	3/8	1/2	3/4	1	1 1/4	1 1/2	2	2 1/2	3	4	
3000	A		7/8	7/8	31/32	1 1/8	1 5/16	1 1/2	1 3/4	2	2 3/8	3	3 3/8	4 3/16
	B		29/32	29/32	1 1/16	1 5/16	1 9/16	1 27/32	2 7/32	2 1/2	3 1/32	3 11/16	4 3/8	5 3/4
	C		0.420	0.555	0.690	0.855	1.065	1.330	1.675	1.915	2.406	2.906	3.535	4.545
	D MIN.		3/8	3/8	3/8	3/8	1/2	1/2	1/2	3/8	5/8	5/8	5/8	3/4
	E		7/16	7/16	17/32	5/8	3/4	7/8	1 1/16	1 1/4	1 1/2	1 5/8	2 1/4	2 5/8
	WEIGHT		0.25	0.21	0.26	0.45	0.75	1.05	1.52	2.08	3.37	6.67	11.08	22.59
6000	A		7/8	31/32	1 1/8	1 5/16	1 1/2	1 3/4	2	2 3/8	2 1/2	3 1/4	3 3/4	4 1/2
	B		29/32	1 1/16	1 5/16	1 9/16	1 27/32	2 7/32	2 1/2	3 1/32	3 11/32	4	4 3/4	6
	C		0.420	0.555	0.690	0.855	1.065	1.330	1.675	1.915	2.406	2.906	3.535	4.545
	D MIN.		3/8	3/8	3/8	3/8	1/2	1/2	1/2	5/8	5/8	5/8	3/4	
	E		7/16	17/32	5/8	3/4	7/8	1 1/16	1 1/4	1 1/2	1 5/8	2 1/4	2 1/2	2 3/4
	WEIGHT		0.26	0.59	0.97	1.42	2.33	2.96	5.71	6.42	12.16	18.69	34.15	
9000	A				1 1/2	1 3/4	2	2 3/8	2 1/2	3				
	B				1 27/32	2 7/32	2 1/2	3 1/32	3 11/32	3 11/16				
	C				0.855	1.065	1.330	1.675	1.915	2.406				
	D MIN.				3/8	1/2	1/2	1/2	1/2	5/8				
	E				1	1 1/8	1 1/4	1 3/8	1 1/2	2 1/8				
	WEIGHT				1.70	2.79	3.81	5.71	8.15	11.26				

Note: 1. All Dimensions are in inches
 2. Weights based on carbon steel (A105)

B[®] 45° ELBOW

BONNEY FORGE

CLASS 2000
CLASS 3000
CLASS 6000
CLASS 9000

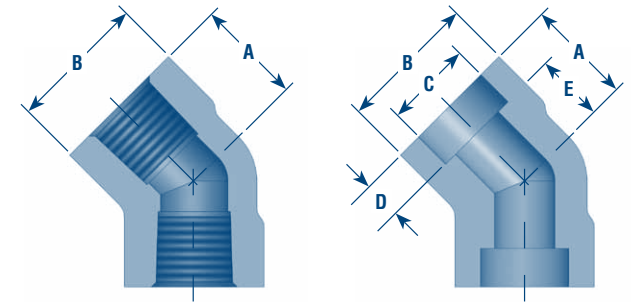
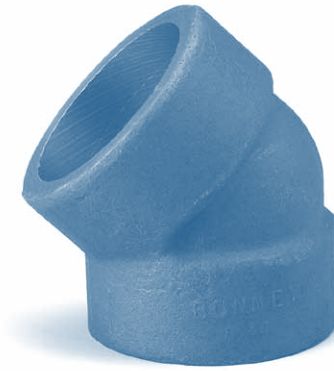

SPECIFICATIONS:
ASME B16.11
ASME B1.20.1 - (NPT)

Threaded

CLASS	DIMENSIONS	SIZES (INCHES)													
		1/8	1/4	3/8	1/2	3/4	1	1 1/4	1 1/2	2	2 1/2	3	4		
2000	A			3/4	3/4	1	1 1/8	1 1/4	1 5/16	1 3/8	1 3/4	2 1/16	2 1/2	3 1/8	
	B			29/32	1 1/16	1 5/16	1 9/16	1 27/32	2 7/32	2 1/2	3 1/32	4	4 3/8	6	
	WEIGHT			0.21	0.24	0.47	0.73	1.03	1.46	1.77	3.03	8.07	9.46	24.57	
3000	A			3/4	3/4	1	1 1/8	1 1/4	1 5/16	1 3/8	1 11/16	1 3/4	2 1/16	2 1/2	3 1/8
	B			29/32	1 1/16	1 5/16	1 9/16	1 27/32	2 7/32	2 1/2	3 1/32	3 5/16	4	4 3/4	6
	WEIGHT			0.23	0.30	0.58	0.91	1.29	2.02	2.29	4.54	5.26	7.83	12.99	24.75
6000	A			3/4	1	1 1/8	1 1/4	1 5/16	1 3/8	1 11/16	1 3/4	2 1/16	2 1/2	3 1/8	3 1/8
	B			1 1/16	1 5/16	1 9/16	1 27/32	2 7/32	2 1/2	3 1/32	3 5/16	4	4 3/4	6	6
	WEIGHT			0.56	0.58	0.91	1.54	2.25	2.84	5.12	6.82	10.28	15.00	35.20	24.75

Socket Weld

CLASS	DIMENSIONS	SIZES (INCHES)													
		1/8	1/4	3/8	1/2	3/4	1	1 1/4	1 1/2	2	2 1/2	3	4		
3000	A			3/4	3/4	3/4	1	1 1/8	1 1/4	1 5/16	1 3/8	1 3/4	2 1/16	2 1/2	3 1/8
	B			29/32	29/32	1 1/16	1 5/16	1 9/16	1 27/32	2 7/32	2 1/2	3 1/32	4	4 3/8	6
	C			0.420	0.555	0.690	0.855	1.065	1.330	1.675	1.915	2.406	2.906	3.535	4.545
	D MIN.			3/8	3/8	3/8	3/8	1/2	1/2	1/2	5/8	5/8	5/8	3/4	
	E			5/16	5/16	5/16	7/16	1/2	9/16	11/16	13/16	1	1 1/8	1 1/4	1 5/8
	WEIGHT			0.22	0.19	0.22	0.42	0.70	0.95	1.39	1.68	2.96	7.76	8.55	24.06
6000	A			3/4	3/4	1	1 1/8	1 1/4	1 5/16	1 3/8	1 3/4	1 27/32	2 1/16	2 1/2	3 1/8
	B			29/32	1 1/16	1 5/16	1 9/16	1 27/32	2 7/32	2 1/2	3 1/32	3 3/8	4	4 3/4	6
	C			0.420	0.555	0.690	0.855	1.065	1.330	1.675	1.915	2.406	2.906	3.535	4.545
	D MIN.			3/8	3/8	3/8	3/8	1/2	1/2	1/2	5/8	5/8	5/8	3/4	
	E			5/16	5/16	7/16	1/2	9/16	11/16	13/16	1	1 1/8	1 1/4	1 3/8	1 5/8
	WEIGHT			0.22	0.48	0.89	1.26	2.00	2.29	4.49	5.57	8.69	14.20	24.06	
9000	A					1 1/4	1 5/16	1 3/8	1 3/4	1 27/32	2 1/16				
	B					1 27/32	2 7/32	2 1/2	3 1/32	3 3/8	4				
	C					0.855	1.065	1.330	1.675	1.915	2.406				
	D MIN.					3/8	1/2	1/2	1/2	1/2	5/8				
	E					5/8	3/4	13/16	7/8	1	1 1/8				
	WEIGHT					1.31	2.37	2.91	4.31	6.89	10.84				

Note: 1. All Dimensions are in inches
 2. Weights based on carbon steel (A105)

CLASS 2000
CLASS 3000
CLASS 6000
CLASS 9000

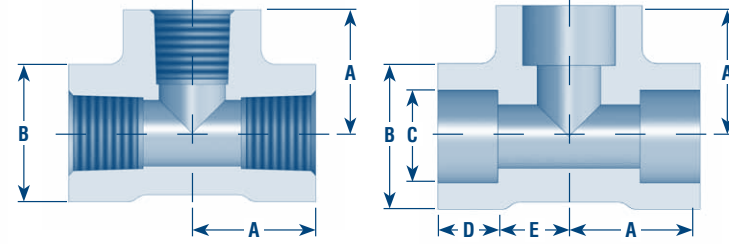
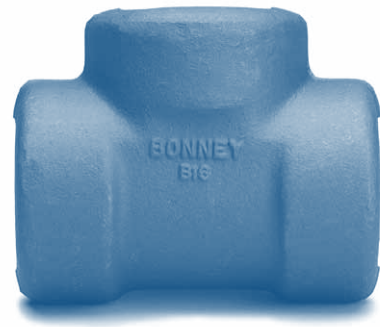

SPECIFICATIONS:
ASME B16.11
ASME B1.20.1 - (NPT)

Threaded

CLASS	DIMENSIONS	SIZES (INCHES)												
		1/8	1/4	3/8	1/2	3/4	1	1 1/4	1 1/2	2	2 1/2	3	4	
2000	A		7/8	31/32	1 1/8	1 5/16	1 1/2	1 3/4	2	2 3/8	3	3 3/8	4 3/16	
	B		29/32	1 1/16	1 5/16	1 9/16	1 27/32	2 7/32	2 1/2	3 1/32	3 11/16	4 5/16	5 3/4	
	WEIGHT		0.29	0.38	0.63	0.95	1.41	2.13	2.91	4.41	9.89	14.17	29.70	
3000	A		7/8	31/32	1 1/8	1 5/16	1 1/2	1 3/4	2	2 3/8	2 1/2	3 1/4	3 3/4	4 1/2
	B		29/32	1 1/16	1 5/16	1 9/16	1 27/32	2 7/32	2 1/2	3 1/32	1 11/32	4	4 3/4	6
	WEIGHT		0.36	0.47	0.77	1.29	1.89	3.08	3.73	7.00	7.63	14.67	22.65	40.08
6000	A		31/32	1 1/8	1 5/16	1 1/2	1 3/4	2	2 3/8	2 1/2	3 1/4	3 3/4	4 3/16	4 1/2
	B		1 1/16	1 5/16	1 9/16	1 27/32	2 7/32	2 1/2	3 1/32	3 11/32	4	4 3/4	5 3/4	6
	WEIGHT		0.47	0.87	1.45	2.24	3.71	4.92	8.13	10.11	19.16	30.43	47.55	47.77

Socket Weld

CLASS	DIMENSIONS	SIZES (INCHES)												
		1/8	1/4	3/8	1/2	3/4	1	1 1/4	1 1/2	2	2 1/2	3	4	
3000	A		7/8	7/8	31/32	1 1/8	1 5/16	1 1/2	1 3/4	2	2 3/8	3	3 3/8	4 3/16
	B		29/32	29/32	1 1/16	1 5/16	1 9/16	1 27/32	2 7/32	2 1/2	3 1/32	3 11/16	4 3/8	5 3/4
	C		0.420	0.555	0.690	0.855	1.065	1.330	1.675	1.915	2.406	2.906	3.535	4.545
	D MIN.		3/8	3/8	3/8	3/8	1/2	1/2	1/2	5/8	5/8	5/8	5/8	3/4
	E		7/16	7/16	17/32	5/8	3/4	7/8	1 1/16	1 1/4	1 1/2	1 5/8	2 1/4	2 5/8
	WEIGHT		0.33	0.27	0.34	0.59	0.94	1.29	2.04	2.77	4.11	8.68	13.79	28.60
6000	A		7/8	31/32	1 1/8	1 5/16	1 1/2	1 3/4	2	2 3/8	2 1/2	3 1/4	3 3/4	4 1/2
	B		29/32	1 1/16	1 5/16	1 9/16	1 27/32	2 7/32	2 1/2	3 1/32	3 11/32	4	4 3/4	6
	C		0.420	0.555	0.690	0.855	1.065	1.330	1.675	1.915	2.406	2.906	3.535	4.545
	D MIN.		3/8	3/8	3/8	3/8	1/2	1/2	1/2	5/8	5/8	5/8	3/4	
	E		7/16	17/32	5/8	3/4	7/8	1 1/16	1 1/4	1 1/2	1 5/8	2 1/4	2 1/2	2 3/4
	WEIGHT		0.34	0.80	1.27	1.91	3.17	4.04	7.55	8.19	16.15	24.43	42.79	
9000	A				1 1/2	1 3/4	2	2 3/8	2 1/2	3				
	B				1 27/32	2 7/32	2 1/2	3 1/32	3 11/32	3 11/16				
	C				0.855	1.065	1.330	1.675	1.915	2.406				
	D MIN.				3/8	1/2	1/2	1/2	1/2	5/8				
	E				1	1 1/8	1 1/4	1 3/8	1 1/2	2 1/8				
	WEIGHT				2.31	3.62	5.20	7.55	10.78	15.79				

Note: 1. All Dimensions are in inches
2. Weights based on carbon steel (A105)

CLASS 2000
CLASS 3000
CLASS 6000
CLASS 9000

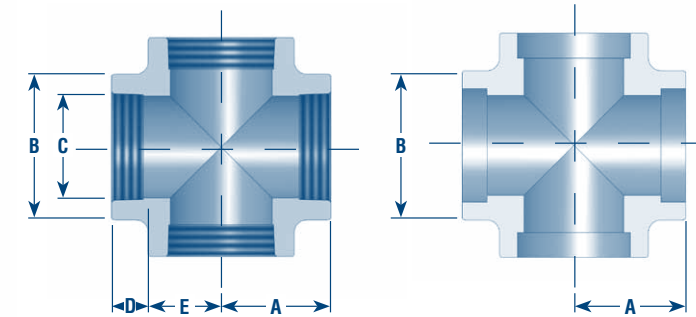

SPECIFICATIONS:
ASME B16.11
ASME B1.20.1 - (NPT)

Threaded

CLASS	DIMENSIONS	SIZES (INCHES)													
		1/8	1/4	3/8	1/2	3/4	1	1 1/4	1 1/2	2	2 1/2	3	4		
2000	A			31/32	31/32	1 1/8	1 5/16	1 1/2	1 3/4	2	2 3/8	3 1/4	3 3/4	4 1/2	
	B			1 1/16	1 1/16	1 5/16	1 9/16	1 27/32	2 7/32	2 1/2	3 1/32	4	4 3/4	6	
	WEIGHT			0.56	0.47	0.83	1.19	1.64	2.46	3.51	5.50	18.32	26.41	45.76	
3000	A			31/32	31/32	1 1/8	1 5/16	1 1/2	1 3/4	2	2 3/8	2 1/2	3 1/4	3 3/4	4 1/2
	B			1 1/16	1 1/16	1 5/16	1 9/16	1 27/32	2 7/32	2 1/2	3 1/32	3 11/32	4	4 3/4	6
	WEIGHT			0.65	0.58	0.97	1.60	2.28	3.65	4.54	8.47	9.10	17.69	26.13	47.37
6000	A			31/32	1 1/8	1 5/16	1 1/2	1 3/4	2	2 3/8	2 1/2	3 1/4	3 3/4	4 1/2	4 1/2
	B			1 1/16	1 5/16	1 9/16	1 27/32	2 7/32	2 1/2	3 1/32	3 11/32	4	4 3/4	6	6
	WEIGHT			0.65	1.19	1.60	2.65	4.34	5.92	10.50	12.12	23.15	28.13	54.00	43.50

Socket Weld

CLASS	DIMENSIONS	SIZES (INCHES)															
		1/8	1/4	3/8	1/2	3/4	1	1 1/4	1 1/2	2	2 1/2	3	4				
3000	A					15/16	15/16	31/32	1 1/8	1 5/16	1 1/2	1 3/4	2	2 3/8	3 1/4	3 3/4	4 1/2
	B					1 1/16	1 1/16	1 1/16	1 5/16	1 9/16	1 27/32	2 7/32	2 1/2	3 1/32	4	4 3/4	6
	C					0.420	0.555	0.690	0.855	1.065	1.330	1.675	1.915	2.406	2.906	3.535	4.545
	D MIN.					3/8	3/8	3/8	3/8	1/2	1/2	1/2	1/2	5/8	5/8	5/8	3/4
	E					7/16	7/16	17/32	5/8	3/4	7/8	1 1/16	1 1/4	1 1/2	1 5/8	2 1/4	2 5/8
	WEIGHT					0.25	0.25	0.42	0.72	1.17	1.49	2.38	3.25	5.08	15.78	24.73	40.00
6000	A								1 5/16	1 1/2	1 3/4	2	2 3/8	2 1/2	3 1/4	3 3/4	
	B								1 9/16	1 27/32	2 7/32	2 1/2	3 1/32	3 11/32	4	4 3/4	
	C								0.855	1.065	1.330	1.675	1.915	2.406	2.906	3.535	
	D MIN.								3/8	1/2	1/2	1/2	5/8	5/8	5/8		
	E								3/4	7/8	1 1/16	1 1/4	1 1/2	1 5/8	2 1/4	2 1/2	
	WEIGHT								1.55	2.31	3.74	5.25	8.80	9.66	16.75	23.00	
9000	A								1 1/2	1 3/4	2	2 3/8	2 1/2	3 1/4			
	B								1 27/32	2 7/32	2 1/2	3 1/32	3 11/32	4			
	C								0.855	1.065	1.330	1.675	1.915	2.406			
	D MIN.								3/8	1/2	1/2	1/2	5/8				
	E								1	1 1/8	1 1/4	1 3/8	1 1/2	2 1/8			
	WEIGHT								1.75	4.12	5.25	5.12	8.75	22.19			

Note: 1. All Dimensions are in inches
2. Weights based on carbon steel (A105)

CLASS 3000
CLASS 6000
CLASS 9000

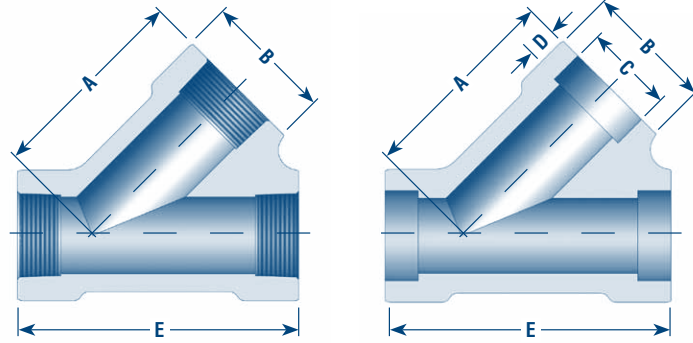

SPECIFICATIONS:
ASME B16.11 - (SOCKET ENDS ONLY)
ASME B1.20.1 - (NPT)

Threaded

CLASS	DIMENSIONS	SIZES (INCHES)								
		1/4	3/8	1/2	3/4	1	1 1/4	1 1/2	2	
3000	A	1 7/8	2 1/8	2 9/16	3	3 1/2	3 15/16	4 3/4	5	
	B	1 1/16	1 5/16	1 9/16	1 27/32	2 7/32	2 1/2	3 1/32	3 11/32	
	E	2 11/16	3	3 9/16	4 1/8	4 13/16	5 3/8	6 7/16	6 5/8	
	WEIGHT		1.00	1.99	2.73	4.43	5.45	11.10	11.70	
6000	A			3	3 1/2	3 15/16	4 3/4	5		
	B			1 27/32	2 7/32	2 1/2	3 1/32	3 11/32		
	E			4 1/8	4 13/16	5 3/8	6 7/16	6 5/8		
	WEIGHT			2.38	3.25	5.44	7.19	12.31		

Socket Weld

CLASS	DIMENSIONS	SIZES (INCHES)								
		1/4	3/8	1/2	3/4	1	1 1/4	1 1/2	2	
3000	A		1 7/8	2 1/8	2 9/16	3	3 1/2	3 15/16	4 3/4	
	B		1 1/16	1 5/16	1 9/16	1 27/32	2 7/32	2 1/2	3 1/32	
	C		0.690	0.855	1.065	1.330	1.675	1.915	2.406	
	D MIN.		3/8	3/8	1/2	1/2	1/2	1/2	5/8	
	E		2 11/16	3	3 9/16	4 1/8	4 13/16	5 3/8	6 7/16	
WEIGHT		1.00	0.88	1.56	2.08	3.08	4.22	6.89		
6000	A			2 9/16	3	3 1/2	3 15/16	4 3/4	5	
	B			1 9/16	1 27/32	2 7/32	2 1/2	3 1/32	3 11/32	
	C			0.855	1.065	1.330	1.675	1.915	2.406	
	D MIN.			3/8	1/2	1/2	1/2	1/2	5/8	
	E			3 9/16	4 1/8	4 13/16	5 3/8	6 7/16	6 5/8	
WEIGHT			2.00	3.07	4.85	6.25	11.94	12.50		
9000	A			3	3 1/2	3 15/16	4 3/4	5		
	B			1 27/32	2 7/32	2 1/2	3 1/32	3 11/32		
	C			0.855	1.065	1.330	1.675	1.915		
	D MIN.			9/16	5/8	11/16	7/8	1/2		
	E			4 1/8	4 13/16	5 3/8	6 7/16	6 5/8		
WEIGHT			1.75	2.38	3.75	6.88	6.88			

Note: 1. All Dimensions are in inches
2. Weights based on carbon steel (A105)

CLASS 3000
CLASS 6000

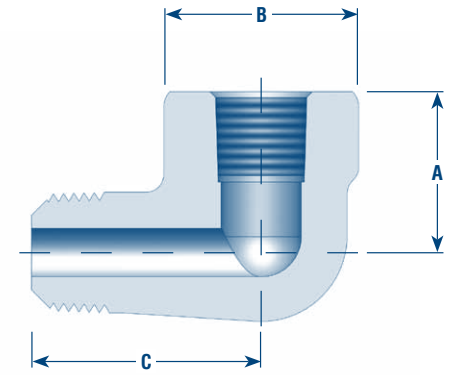

SPECIFICATIONS:
ASME B16.11
ASME B1.20.1 - (NPT)

Threaded

CLASS	DIMENSIONS	SIZES (INCHES)								
		1/8	1/4	3/8	1/2	3/4	1	1 1/4	1 1/2	2
3000	A	7/8	7/8	1	1 1/8	1 3/8	1 3/4	2	2 1/8	2 1/2
	B	1 1/16	1 1/16	1 5/16	1 1/2	1 13/16	2 3/16	2 7/16	3 1/32	3 5/16
	C	1 1/4	1 1/4	1 1/2	1 5/8	1 7/8	2 1/4	2 5/8	2 15/16	3 5/16
	WEIGHT	0.27	0.25	0.41	0.61	1.02	1.73	2.42	4.05	5.25
6000	A	7/8	1	1 1/8	1 3/8	1 3/4	2	2 1/8	2 1/2	
	B	1 1/16	1 5/16	1 1/2	1 13/16	2 3/16	2 7/16	3 1/32	3 5/16	
	C	1 1/4	1 1/2	1 5/8	1 7/8	2 1/4	2 5/8	2 15/16	3 5/16	
	WEIGHT	0.42	0.44	0.69	1.18	2.09	3.12	4.87	7.04	

Note: 1. All Dimensions are in inches
2. Weights based on carbon steel (A105)

CLASS 3000
CLASS 6000

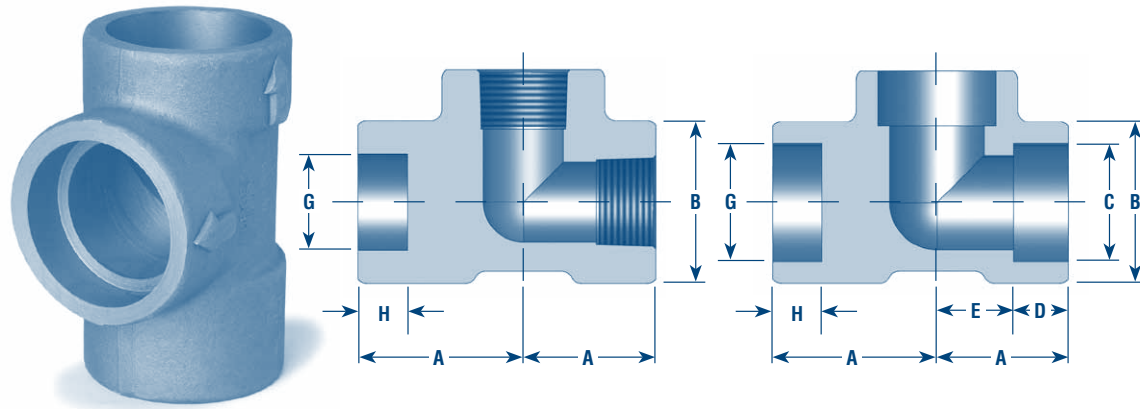

SPECIFICATIONS:
ASME B16.11 - (SOCKET DIMENSIONS ONLY)
ASME B1.20.1 - (NPT)

Threaded

CLASS	DIMENSIONS	SIZES (INCHES)					
		1/2	3/4	1	1 1/4	1 1/2	2
3000	A	1 1/2	1 1/2	2	2	2 3/8	2 1/2
	B	1 7/8	1 7/8	2 1/2	2 1/2	3	3 1/8
	F	1 7/8	1 7/8	2 1/2	2 1/2	3	3 1/4
	G	0.855	1.065	1.330	1.675	1.915	2.406
	H	1/2	9/16	3/4	3/4	3/4	7/8
	WEIGHT	2.63	2.19	6.02		5.10	10.31
6000	A	1 1/2	2	2	2 3/8	2 1/2	
	B	1 7/8	2 1/2	2 1/2	3	3 1/8	
	F	1 7/8	2 1/2	2 1/2	3	3 1/8	
	G	0.855	1.065	1.330	1.675	1.915	
	H	9/16	3/4	3/4	3/4	7/8	
	WEIGHT		6.53			10.31	

Socket Weld

CLASS	DIMENSIONS	SIZES (INCHES)					
		1/2	3/4	1	1 1/4	1 1/2	2
3000	A	1 1/2	1 1/2	1 1/2	2	2	2 3/8
	B	1 7/8	1 7/8	1 7/8	2 1/2	2 1/2	3
	C	0.855	1.065	1.330	1.675	1.915	2.406
	D MIN.	3/8	1/2	1/2	1/2	1/2	5/8
	E	5/8	3/4	7/8	1 1/4	1 1/4	1 1/2
	F	1 7/8	1 7/8	1 7/8	2 1/2	2 1/2	3
	G	0.855	1.065	1.330	1.675	1.915	2.406
	H	9/16	9/16	9/16	3/4	3/4	3/4
	WEIGHT		2.03	2.63		3.89	6.33
6000	A		1 1/2	2	2 3/8	2 3/8	2 1/2
	B		1 7/8	2 1/2	3	3	3 3/8
	C		1.065	1.330	1.675	1.915	2.406
	D MIN.		1/2	1/2	1/2	1/2	5/8
	E		7/8	1 1/16	1 1/4	1 1/2	1 5/8
	F		1 7/8	2 1/2	3	3	3 1/8
	G		1.065	1.330	1.675	1.915	2.406
	H		9/16	3/4	9/16	9/16	11/16
	WEIGHT		2.19	6.02		4.75	10.98

Note: 1. All Dimensions are in inches
2. Weights based on carbon steel (A105)

CLASS 3000
CLASS 6000

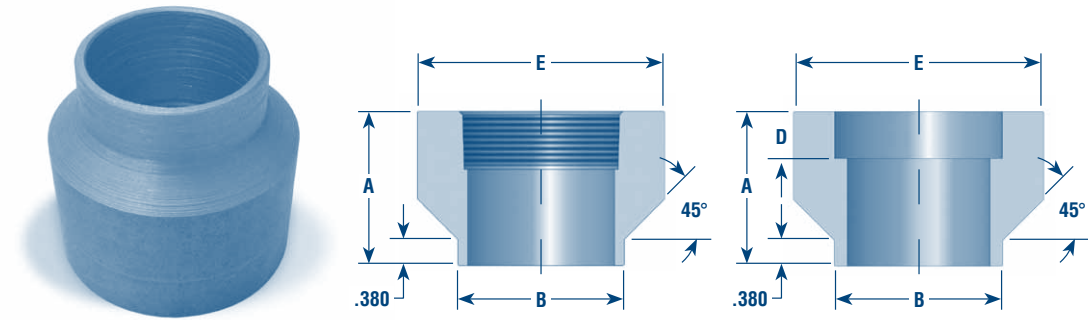

SPECIFICATIONS:
ASME B16.11 - (SOCKET DIMENSIONS ONLY)
ASME B1.20.1 - (NPT)

Threaded

CLASS	DIMENSIONS	SIZES (INCHES)										
		1/8	1/4	3/8	1/2	3/4	1	1 1/4	1 1/2	2	2 1/2	3
3000	A		1 3/16	1 3/16	1 5/16	1 3/8	1 11/16	1 7/8	2	2 1/4	2 1/2	2 3/4
	B		11/16	13/16	15/16	1 1/16	1 5/16	1 11/16	1 15/16	2 7/16	2 7/8	3 1/2
	E		1	1 1/16	1 3/8	1 1/2	1 13/16	2 1/4	2 1/2	3 1/8	3 5/8	4 3/8
	WEIGHT		0.13	0.21	0.29	0.29	0.51	0.84	1.18	2.04	2.93	4.11
6000	A	1 3/16	1 3/16	1 3/16	1 5/16	1 3/8	1 11/16	1 7/8	2	2 1/4	2 1/2	2 3/4
	B	9/16	11/16	13/16	15/16	1 1/16	1 5/16	1 11/16	1 15/16	2 7/16	2 7/8	3 1/2
	E	7/8	1	1 1/4	1 1/2	1 3/4	2 1/4	2 1/2	3	3 5/8	4 1/4	5
	WEIGHT	0.12	0.15	0.20	0.33	0.43	0.93	1.15	1.86	3.02	4.40	6.40

Socket Weld

CLASS	DIMENSIONS	SIZES (INCHES)										
		1/8	1/4	3/8	1/2	3/4	1	1 1/4	1 1/2	2	2 1/2	3
3000	A		1 3/16	1 3/16	1 5/16	1 3/8	1 11/16	1 7/8	2	2 1/4	2 1/2	2 3/4
	B		11/16	13/16	15/16	1 1/16	1 5/16	1 11/16	1 15/16	2 7/16	2 7/8	3 1/2
	D MIN.		3/8	3/8	3/8	1/2	1/2	1/2	1/2	5/8	5/8	5/8
	E		15/16	1 1/16	1 5/16	1 1/2	1 13/16	2 1/4	2 1/2	3 1/8	3 5/8	4 3/8
	F		0.555	0.690	0.855	1.065	1.330	1.675	1.915	2.406	2.906	3.535
	WEIGHT		0.13	0.21	0.29	0.29	0.51	0.84	1.18	2.04	2.93	4.11
6000	A	1 3/16	1 3/16	1 3/16	1 5/16	1 3/8	1 11/16	1 7/8	2	2 1/4	2 1/2	2 3/4
	B	9/16	11/16	13/16	15/16	1 1/16	1 5/16	1 11/16	1 15/16	2 7/16	2 7/8	3 1/2
	D MIN.	3/8	3/8	3/8	3/8	1/2	1/2	1/2	1/2	5/8	5/8	5/8
	E	7/8	1	1 1/4	1 1/2	1 3/4	2 1/4	2 1/2	3	3 5/8	4 1/4	5
	F	0.420	0.555	0.690	0.855	1.065	1.340	1.675	1.915	2.406	2.906	3.535
	WEIGHT	0.18	0.16	0.22	0.33	0.43	0.93	1.24	1.91	3.07	4.83	6.83

Note: 1. All Dimensions are in inches
2. Weights based on carbon steel (A105)

B SOCKET WELD COUPLINGS, REDUCERS AND CAPS

BONNEY FORGE

CLASS 3000

CLASS 6000

CLASS 9000

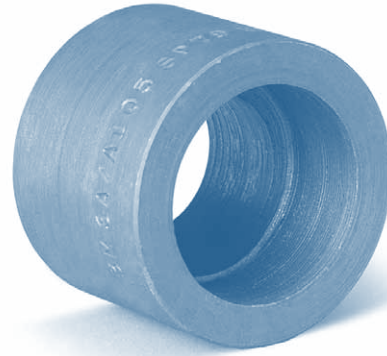

**SPECIFICATIONS:
ASME B16.11**

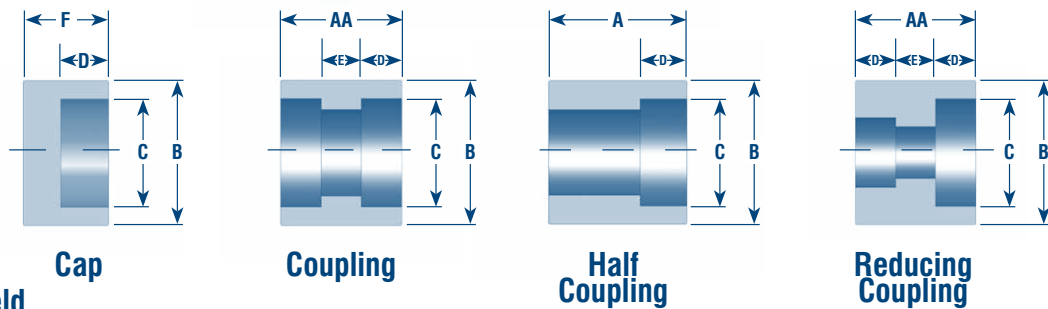

Socket Weld

CLASS	DIMENSIONS	SIZES (INCHES)											
		1/8	1/4	3/8	1/2	3/4	1	1 1/4	1 1/2	2	2 1/2	3	4
3000	A	1 1/16	1 1/16	1 1/8	1 3/8	1 1/2	1 3/4	1 7/8	2	2 1/2	2 9/16	2 3/4	3
	AA	1 1/32	1 1/32	1 1/32	1 3/16	1 13/32	1 33/64	1 33/64	1 33/64	2 1/64	2 1/64	2 1/64	2 17/64
	B	3/4	7/8	1 1/16	1 1/4	1 1/2	1 13/16	2 1/4	2 1/2	3	3 5/8	4 5/16	5 1/2
	C	0.420	0.555	0.690	0.855	1.065	1.330	1.675	1.915	2.406	2.906	3.535	4.545
	D MIN.	3/8	3/8	3/8	3/8	1/2	1/2	1/2	1/2	5/8	5/8	5/8	3/4
	E	1/4	1/4	1/4	3/8	3/8	1/2	1/2	1/2	3/4	3/4	3/4	3/4
F	11/16	3/4	3/4	7/8	1	1 1/16	1 3/16	1 1/4	1 1/2	1 9/16	1 13/16	2 1/16	
COUPLING	WEIGHT	0.09	0.12	0.16	0.24	0.39	0.57	0.90	1.04	1.79	2.906	4.06	5.73
HALF COUPLING	WEIGHT	0.10	0.13	0.18	0.32	0.46	0.75	1.24	1.33	2.38	3.55	6.24	8.30
REDUCER	WEIGHT		0.12	0.16	0.24	0.39	0.57	0.90	1.04	1.79	2.42	4.06	5.73
CAP	WEIGHT	0.07	0.10	0.14	0.22	0.36	0.55	1.01	1.27	1.99	3.38	6.30	12.08

6000	A	1 1/16	1 1/16	1 1/8	1 3/8	1 1/2	1 3/4	1 7/8	2	2 1/2	2 9/16	2 3/4	3
	AA	1 1/16	1 1/8	1 1/8	1 5/32	1 13/32	1 33/64	1 33/64	1 33/64	2 1/64	2 1/64	2 1/64	2 17/64
	B	7/8	1 1/16	1 5/16	1 1/2	1 3/4	2 1/4	2 1/2	3	3 5/8	4 1/4	5	6 1/4
	C	0.420	0.555	0.690	0.855	1.065	1.330	1.675	1.915	2.406	2.906	3.535	4.545
	D MIN.	3/8	3/8	3/8	3/8	1/2	1/2	1/2	1/2	5/8	5/8	5/8	3/4
	E	1/4	1/4	1/4	3/8	3/8	1/2	1/2	1/2	3/4	3/4	3/4	3/4
F		15/16	15/16	1	1 1/16	1 1/4	1 5/16	1 3/8	1 5/8	1 11/16	1 15/16	2 5/16	
COUPLING	WEIGHT		0.23	0.33	0.45	0.67	1.27	1.37	2.09	3.85	4.93	6.69	8.00
HALF COUPLING	WEIGHT				0.56	0.80	1.58	1.72	2.99	4.99	5.44	9.50	12.64
REDUCER	WEIGHT		0.23	0.33	0.45	0.67	1.27	1.37	2.09	3.85	4.93	6.69	8.00
CAP	WEIGHT		0.20	0.27	0.42	0.58	1.18	1.41	2.19	3.65	5.63	8.78	14.25

9000	A				1 3/8	1 1/2	1 3/4	1 51/64	2	2 1/2			
	AA				1 3/8	1 1/2	1 3/4	1 51/64	2	2 1/2			
	B				1 13/16	2	2 3/8	2 3/4	3 1/16	3 5/8			
	C				0.855	1.065	1.330	1.675	1.915	2.406			
	D MIN.				3/8	1/2	1/2	1/2	1/2	5/8			
E				3/8	3/8	1/2	1/2	1/2	3/4				
COUPLING	WEIGHT				0.62	1.04	1.71	1.69	2.93	4.61			
HALF COUPLING	WEIGHT				0.88	0.80	1.74	2.22	2.93	4.99			
REDUCER	WEIGHT				0.62	1.04	1.71	1.69	2.93	4.61			

- Note:
1. All dimensions are in inches.
 2. Weights based on carbon steel (A105)
 3. Reducer weights shown are based on full coupling sizes.
 4. Reducers smaller than 1/4" are not offered.

B THREADED COUPLINGS, REDUCERS AND CAPS

BONNEY FORGE

CLASS 3000

CLASS 6000

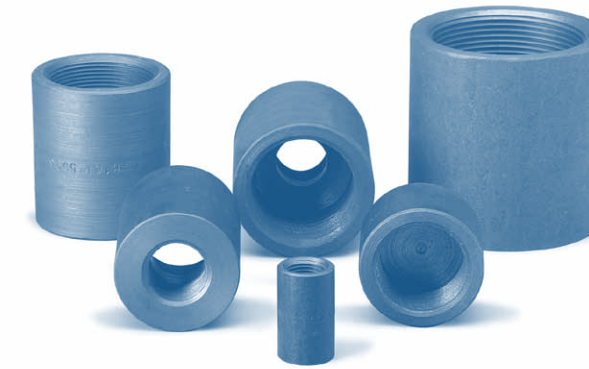

**SPECIFICATIONS:
ASME B16.11
ASME B1.20.1 - (NPT)**

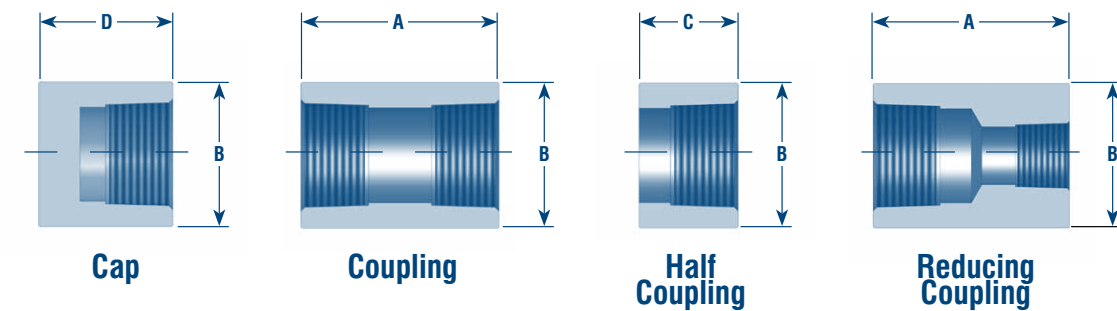

Threaded

CLASS	DIMENSIONS	SIZES (INCHES)											
		1/8	1/4	3/8	1/2	3/4	1	1 1/4	1 1/2	2	2 1/2	3	4
3000	A	1 1/4	1 3/8	1 1/2	1 7/8	2	2 3/8	2 5/8	3 1/8	3 3/8	3 5/8	4 1/4	4 3/4
	B	3/4	3/4	7/8	1 1/8	1 3/8	1 3/4	2 1/4	2 1/2	3	3 5/8	4 1/4	5 1/2
	C	5/8	11/16	3/4	15/16	1	1 3/16	1 5/16	1 9/16	1 11/16	1 13/16	2 1/8	2 3/8
	D	15/16	1	1	1 1/4	1 7/16	1 5/8	1 3/4	1 3/4	1 7/8	2 3/8	2 9/16	2 11/16
COUPLING	WEIGHT	0.13	0.11	0.13	0.29	0.42	0.85	1.60	2.26	2.95	4.61	6.89	12.48
HALF COUPLING	WEIGHT	0.06	0.05	0.06	0.13	0.21	0.42	0.79	1.12	1.53	2.34	3.26	6.48
REDUCER	WEIGHT		0.11	0.13	0.29	0.42	0.85	1.60	2.26	2.95	4.61	6.89	12.48
CAP	WEIGHT	0.10	0.09	0.10	0.24	0.37	0.74	1.35	1.64	2.40	4.45	7.14	12.42

6000	A	1 1/4	1 3/8	1 1/2	1 7/8	2	2 3/8	2 5/8	3 1/8	3 3/8	3 5/8	4 1/4	4 3/4
	B	7/8	1	1 1/4	1 1/2	1 3/4	2 1/4	2 1/2	3	3 5/8	4 1/4	5	6 1/4
	C	5/8	11/16	3/4	15/16	1	1 3/16	1 5/16	1 9/16	1 11/16	1 13/16	2 1/8	2 3/8
	D	1	1 1/16	1 1/16	1 5/16	1 1/2	1 11/16	1 13/16	1 7/8	2	2 1/2	2 11/16	2 15/16
COUPLING	WEIGHT	0.18	0.28	0.39	0.70	0.95	1.93	2.28	4.20	6.00	8.65	13.41	21.86
HALF COUPLING	WEIGHT	0.10	0.12	0.19	0.35	0.49	0.97	1.15	2.08	3.05	4.35	6.83	7.05
REDUCER	WEIGHT		0.28	0.39	0.70	0.95	1.93	2.28	4.20	6.00	8.65	13.41	21.86
CAP	WEIGHT	0.16	0.23	0.31	0.55	0.78	1.55	1.90	2.79	4.35	8.10	10.73	15.58

- Note:
1. All dimensions are in inches.
 2. Weights based on carbon steel (A105)
 3. Reducer weights shown are based on full coupling sizes.
 4. Reducers smaller than 1/4" are not offered.

CLASS 3000
CLASS 6000

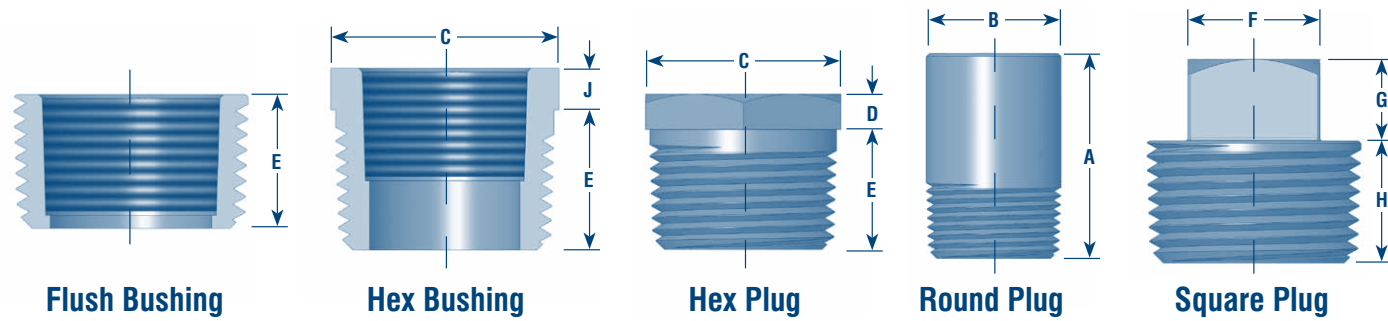
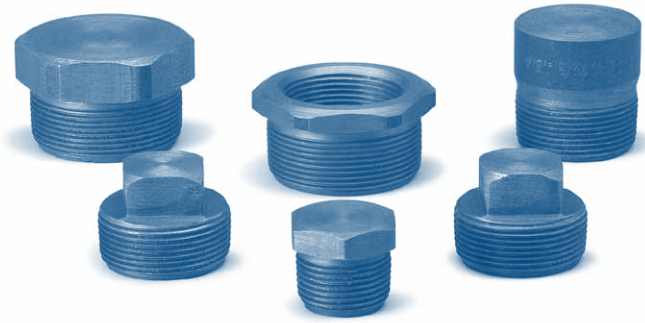

SPECIFICATIONS:
ASME B16.11
ASME B1.20.1 - (NPT)

CLASS	DIMENSIONS	SIZES (INCHES)											
		1/8	1/4	3/8	1/2	3/4	1	1 1/4	1 1/2	2	2 1/2	3	4
3000/6000	A	1 3/8	1 5/8	1 5/8	1 3/4	1 3/4	2	2	2	2 1/2	2 3/4	2 3/4	3
	B	13/32	9/16	11/16	13/16	1 1/16	1 5/16	1 11/16	1 29/32	2 3/8	2 7/8	3 1/2	4 1/2
	C	7/16	5/8	11/16	7/8	1 1/16	1 3/8	1 3/4	2	2 1/2	3	3 3/4	4 7/8
	D MIN.	1/4	1/4	5/16	5/16	3/8	3/8	9/16	5/8	11/16	3/4	13/16	1
	E	7/16	1/2	9/16	11/16	3/4	27/32	7/8	15/16	1	1 1/4	1 11/16	1 25/32
	F	9/32	3/8	7/16	9/16	5/8	13/16	15/16	1 1/8	1 5/16	1 1/2	1 11/16	2 1/2
	G	1/4	1/4	5/16	3/8	7/16	1/2	9/16	5/8	11/16	3/4	13/16	1 1/4
	H	3/8	7/16	1/2	9/16	5/8	3/4	13/16	13/16	7/8	1 1/16	1 1/8	1 1/4
	J MIN.		3/16	3/16	3/16	1/4	1/4	3/8	3/8	3/8	1/2	7/16	1
	ROUND PLUG	WEIGHT	0.05	0.11	0.18	0.25	0.41	0.73	1.20	1.57	3.10	5.01	7.40
HEXAGON PLUG	WEIGHT	0.03	0.06	0.09	0.16	0.27	0.48	0.93	1.35	2.26	3.84	7.08	12.07
SQUARE PLUG	WEIGHT	0.02	0.04	0.06	0.12	0.19	0.35	0.61	0.83	1.41	2.33	3.57	6.28
HEX BUSHING	WEIGHT		0.03	0.04	0.06	0.12	0.21	0.38	0.37	0.77	1.31	3.78	7.31
FLUSH BUSHING	WEIGHT		0.05	0.07	0.03	0.06	0.09	0.17	0.19	0.39	0.62	1.00	1.88

Note: 1. All Dimensions are in inches
2. Weights based on carbon steel (A105)

CLASS 3000
CLASS 6000
CLASS 9000



SPECIFICATIONS:
MSS SP-79
ASME B16.11 - (SOCKET DIMENSIONS ONLY)

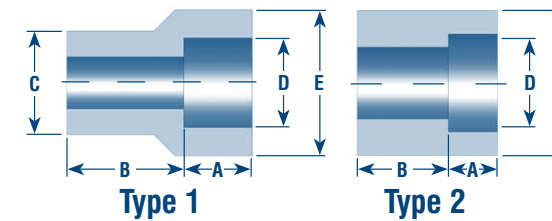

SIZE	C	D	3000			6000			9000			WEIGHT						
			Fig. Type	A (Min.)	B	E	Fig. Type	A (Min.)	B	E	Fig. Type	A (Min.)	B	E	3000	6000	9000	
3/8 x 1/4	0.685	0.555	1	3/8	3/4	15/16	1	3/8	27/32	1				0.12	0.20			
1/2 x 3/8	0.850	0.690	1	3/8	13/16	1 1/16	1	3/8	29/32	1 3/16				0.16	0.19			
1/2 x 1/4	0.850	0.555	1	3/8	13/16	15/16	1	3/8	13/16	1				0.17	0.19			
3/4 x 1/2	1.060	0.855	1	3/8	7/8	15/16	1	3/8	1	1 3/8	1	3/8	1 3/16	1 3/4	0.26	0.36	0.62	
3/4 x 3/8	1.060	0.690	2	3/8	5/8		1	3/8	7/8	1 3/16				0.19	0.25			
3/4 x 1/4	1.060	0.555	2	3/8	11/16		2	3/8	7/8					0.23	0.27			
1 x 3/4	1.325	1.065	1	1/2	15/16	1 17/32	1	1/2	1 1/8	1 11/16	1	1/2	1 1/4	2	0.38	0.60	1.10	
1 x 1/2	1.325	0.855	2	3/8	5/8		1	3/8	1 1/8	1 3/8	1	3/8	1 1/8	1 3/4	0.32	0.49	0.74	
1 x 3/8	1.325	0.690	2	3/8	11/16		2	3/8	7/8						0.37	0.41		
1 x 1/4	1.325	0.555	2	3/8	3/4		2	3/8	15/16						0.41	0.50		
1 1/4 x 1	1.670	1.330	1	1/2	1	1 7/8	1	1/2	1 3/16	2		1	1/2	1 3/8	2 3/8	0.62	0.89	1.44
1 1/4 x 3/4	1.670	1.065	2	1/2	11/16		2	1/2	13/16			1	1/2	1 3/16	2	0.54	1.04	1.81
1 1/4 x 1/2	1.670	0.855	2	3/8	3/4		2	3/8	7/8			2	3/8	7/8		0.65	0.95	1.14
1 1/4 x 3/8	1.670	0.690	2	3/8	13/16		2	3/8	15/16							0.70	1.04	
1 1/4 x 1/4	1.670	0.555	2	3/8	7/8		2	3/8	1							0.75	1.14	
1 1/2 x 1 1/4	1.910	1.675	1	1/2	1 1/8	2 1/4	1	1/2	1 3/8	2 3/8	1	1/2	1 5/8	2 3/4	0.80	1.23	1.90	
1 1/2 x 1	1.910	1.330	2	1/2	11/16		1	1/2	1 5/32	2 1/16	1	1/2	1 3/8	2 3/8	0.68	1.13	1.13	
1 1/2 x 3/4	1.910	1.065	2	1/2	3/4		2	1/2	1			2	1/2	1	0.84	1.04	1.23	
1 1/2 x 1/2	1.910	0.855	2	3/8	13/16		2	3/8	1 1/16			2	3/8	1	0.97	1.15	1.33	
1 1/2 x 3/8	1.910	0.690	2	3/8	7/8		2	3/8	1 1/8						1.00	1.25		
2 x 1 1/2	2.385	1.915	1	1/2	1 1/4	2 1/2	1	1/2	1 17/32	2 11/16	1	1/2	2 1/16	3	1.24	1.93	2.43	
2 x 1 1/4	2.385	1.675	2	1/2	13/16		2	1/2	15/16			1	1/2	2	1.16	1.36	1.96	
2 x 1	2.385	1.330	2	1/2	7/8		2	1/2	1			2	1/2	1	1.50	1.86	1.54	
2 x 3/4	2.385	1.065	2	1/2	15/16		2	1/2	1 1/16			2	1/2	1 1/16	1.69	1.82	1.82	
2 x 1/2	2.385	0.855	2	3/8	1		2	3/8	1 1/8			2	3/8	1 1/8	1.81	1.92	1.92	

Note: 1. All dimensions are in inches.
2. Weights based on carbon steel (A105)
3. Larger sizes are available upon request, and are supplied in accordance to MSS SP-79.

CLASS 3000
CLASS 6000

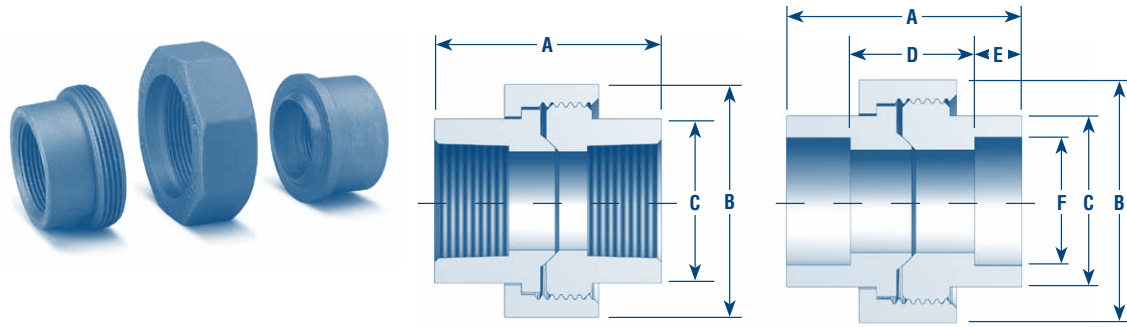

SPECIFICATIONS:
ASME B16.11
ASME B1.20.1 - (NPT)

CLASS	DIMENSIONS	SIZES (INCHES)										
		1/8	1/4	3/8	1/2	3/4	1	1 1/4	1 1/2	2	2 1/2	3
3000	A	1 45/64	1 23/32	1 7/8	2	2 9/32	2 1/2	2 7/8	3 1/32	3 1/2	4 3/64	4 19/64
	B	1 3/8	1 3/8	1 9/16	1 13/16	2 11/64	2 9/16	3 1/8	3 1/2	4 1/4	4 7/8	5 3/4
	C	7/8	7/8	1 1/32	1 15/64	1 31/64	1 13/16	2 15/64	2 31/64	3 1/32	3 21/32	4 13/32
	D	61/64	31/32	1 1/8	1 1/4	1 9/32	1 1/2	1 7/8	2 1/32	2 1/4	2 51/64	3 3/64
	E MIN.	3/8	3/8	3/8	3/8	1/2	1/2	1/2	1/2	5/8	5/8	5/8
	F	0.420	0.555	0.690	0.855	1.065	1.330	1.675	1.915	2.406	2.906	3.535
	WEIGHT	0.41	0.38	0.54	0.79	1.25	1.80	2.88	3.64	5.81	8.77	12.98
6000	A		1 7/8	1 63/64	2 19/64	2 1/2	2 7/8	3 1/64	3 17/32	4 17/64		
	B		1 37/64	1 13/16	2 13/64	2 37/64	3 7/64	3 27/64	4 3/32	4 7/8		
	C		1 1/32	1 15/64	1 15/32	1 51/64	2 11/64	2 15/32	3 1/32	3 21/32		
	D		1 1/8	1 15/64	1 35/64	1 1/2	1 7/8	2 1/64	2 17/32	3 1/64		
	E MIN.		3/8	3/8	3/8	1/2	1/2	1/2	1/2	5/8		
	F		0.555	0.690	0.855	1.065	1.330	1.675	1.915	2.406		
	WEIGHT		0.59	0.84	1.42	2.09	3.40	4.09	7.18	12.44		

Note: 1. The "B" Dimensions is measured across the flats of the union nut.
2. All Dimensions are in inches
3. Weights based on carbon steel (A105)

TYPE 601
TYPE 602
TYPE 602B
TYPE 604

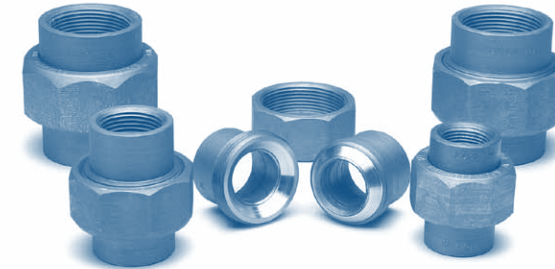

- FEATURES:
- Ideal for Steam Service
 - Designs rated for 3000 WOG / 600 WSP
 - Ball-to-Cone Seats for smooth alignment
 - Can be repeatedly assembled and disassembled
 - Replaceable and interchangeable parts
 - Carbon steel components are coated to resist corrosion
 - Stays sealed - regardless of shock, vibration, expansion and rough wrenching
 - Silicon Bronze and Stainless Steel seats double locked under 120,000 lbs. psi
 - Conveniently packaged
 - Suitable for use with Schedule 40/80 pipe
 - 100% hydro tested
 - Type 604 is preferred over bronze to carbon steel seated unions

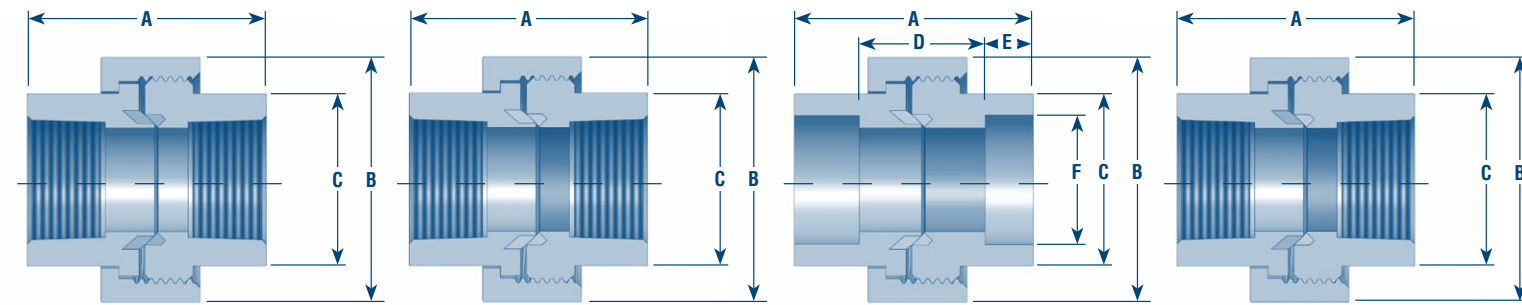





Type 601 Type 602 Type 602B Type 604

SPECIFICATIONS:
ASME B16.11 - (SOCKET DIMENSIONS ONLY)
ASME B1.20.1 - (NPT)

TYPE	DIMENSIONS	SIZES (INCHES)									
		1/8 18-NPT	1/4 18-NPT	3/8 18-NPT	1/2 14-NPT	3/4 14-NPT	1 11 1/2-NPT	1 1/4 11 1/2-NPT	1 1/2 11 1/2-NPT	2 11 1/2-NPT	
TYPE 601, 602, 604	A	1 7/8	1 7/8	2	2 5/32	2 25/64	2 25/32	2 31/32	3 5/64	3 21/32	
	B	1 1/4	1 1/4	1 3/8	1 21/32	2	2 3/8	2 3/4	3	3 23/32	
	C	3/4	3/4	29/32	1 7/64	1 27/64	1 41/64	2 1/32	2 5/16	2 13/16	
	STYLE NUT	HEX	HEX	HEX	HEX	OCTAGON	OCTAGON	OCTAGON	OCTAGON	OCTAGON	
	WEIGHT	0.37	0.34	0.43	0.68	1.06	1.51	2.19	2.58	4.83	
TYPE 602B	A		1 3/4	2	2 11/64	2 7/16	2 3/4	2 15/16	3 7/64	3 21/32	
	B		1 1/4	1 3/8	1 21/32	2	2 3/8	2 3/4	3	3 23/32	
	C		3/4	29/32	1 1/8	1 27/64	1 41/64	2 1/32	2 5/16	2 13/16	
	D		1	1 1/4	1 27/64	1 7/16	1 3/4	1 15/16	2 7/64	2 13/32	
	E MIN.		3/8	3/8	3/8	1/2	1/2	1/2	1/2	5/8	
	F		0.555	0.690	0.855	1.065	1.330	1.675	1.915	2.406	
	STYLE NUT		HEX	HEX	HEX	OCTAGON	OCTAGON	OCTAGON	OCTAGON	OCTAGON	
WEIGHT		0.30	0.43	0.68	1.04	1.46	2.09	2.55	4.71		

Note: 1. The "B" Dimension is measured across the flats of the union nut.
2. All Dimensions are in inches
3. Weights based on carbon steel (A105)

Product Comparison

	Type 601	Type 602	Type 602B	Type 604
SEAT MATERIAL	 Silicon Bronze	 Stainless Steel	 Stainless Steel	 Silicon Bronze (male) Stainless (female)
END CONNECTION	Threaded	Threaded	Socket Weld	Threaded

CLASS 3000

CLASS 6000

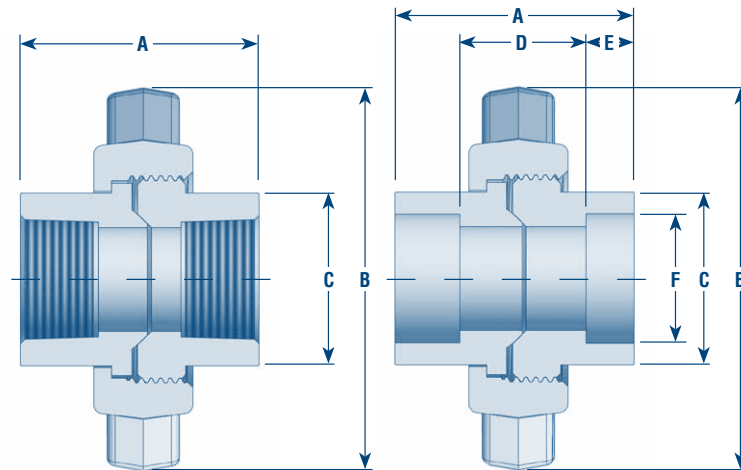
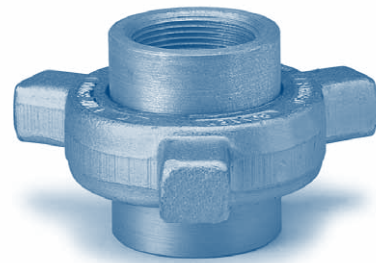

Lug Nut unions from Bonney Forge are supplied with modified Stub Acme threads ideal for applications requiring rapid assembly and/or disassembly.

SPECIFICATIONS:
ASME B16.11 - (SOCKET DIMENSIONS ONLY)
ASME B1.20.1 - (NPT)

CLASS	DIMENSIONS	SIZES (INCHES)									
		3/8	1/2	3/4	1	1 1/4	1 1/2	2	2 1/2	3	4
3000	A	1 7/8	1 63/64	2 19/64	2 57/64	2 29/32	3 1/32	3 31/64	4 1/16	4 31/64	8 1/32
	B	2 9/16	3	3 5/8	4 1/4	5	5 5/8	6 3/8	7 3/16	8	10 23/64
	C	1 1/32	1 15/64	1 31/64	1 13/16	2 3/16	2 15/32	3 1/32	3 21/32	4 13/32	5 29/64
	D	1 1/8	1 15/64	1 19/64	1 57/64	1 29/32	2 1/32	2 15/64	2 13/16	3 15/64	6 17/32
	E MIN.	3/8	3/8	1/2	1/2	1/2	1/2	5/8	5/8	5/8	3/4
	F	0.690	0.855	1.065	1.330	1.675	1.915	2.406	2.906	3.535	4.545
	WEIGHT	0.59	0.91	3.12	2.28	3.48	4.66	7.07	11.40	15.42	
6000	A		2 3/8	2 37/64	2 57/64	3 1/8	3 37/64	4 9/64			
	B		3 5/8	4 1/4	5	5 5/8	6 3/8	7 3/16			
	C		1 15/32	1 51/64	2 11/64	2 9/16	3 1/32	3 11/16			
	D		1 5/8	1 37/64	1 57/64	2 1/8	2 37/64	2 57/64			
	E MIN.		3/8	1/2	1/2	1/2	1/2	5/8			
	F		0.855	1.065	1.330	1.675	1.915	2.406			
	WEIGHT		1.95	2.84	3.96		7.00	14.16			

- Note:
- Seating characteristics of MSS SP-83 unions.
 - The "B" dimension is the diameter across the lugs of the union nut.
 - Twin lug design offered in sizes up to 3/4" Class 3000 & 1/2" Class 6000
 - Tri-Lug design offered in sizes from 1" to 3" Class 3000 & 3/4" to 2" Class 6000.
 - Quad-Lug design offered in 4" Class 3000.

PIPE SCHEDULE – EQUIVALENCY

Pressure Ratings for Bonney Forge Forged Steel Fittings comply with ASME B16.11. The allowable pressure rating for fittings are equivalent to the pressure ratings of the corresponding pipe listed in the table below. The fitting is suitable for the application if the application pipe nominal wall thickness is less than or equal to the nominal thickness of the Schedule No. / Wall Designation listed below.

FITTING CLASS	FITTING CONNECTION	PIPE EQUIVALENT	
		Schedule No.	Wall Designation
2000	Threaded	Sch. 80	XS
3000	Threaded	Sch. 160	-
6000	Threaded	-	XXS
3000	Socket-Weld	Sch. 80	XS
6000	Socket-Weld	Sch. 160	-
9000	Socket-Weld	-	XXS

PIPE PRESSURE CALCULATIONS

ASME B31.1 – 2012	ASME B31.3 - 2012
$P = \frac{2 SE (t_m - A)}{D_o - 2y (t_m - A)}$	$t = \frac{PD}{2(SEW + PY)} \quad \text{or} \quad P = \frac{2(SEW + PY)}{D - 2tY}$
<p>P = Pressure Rating</p> <p>SE = Allowable Stress (@temperature)</p> <p>t_m = Wall Thickness</p> <p>A = Corrosion Allowance (Typically = 0)</p> <p>D_o = Outer Diameter of Pipe</p> <p>Y = Table 104.1.2 (A) of ASME B31.1 (0.4 if temperature is less than 900°F)</p>	<p>P = Pressure Rating</p> <p>D = Outer Diameter of Pipe</p> <p>S = Allowable Stress (@ Temperature): Table A-1</p> <p>E = Quality Factor: Table A-1A or A-1B</p> <p>W = Weld Joint Strength Reduction Factor: Para. 302.3.5(e) (Typically = 1.0)</p> <p>t = Pipe Wall Thickness</p> <p>Y = Table 304.1.1 or Intermediate Temperature Interpolations (Below Equation)</p> $Y = \frac{d + 2c}{D + d + 2c}$ <p>D = Outer Diameter of Pipe</p> <p>d = Inside Diameter of Pipe</p> <p>c = Sum of Mechanical Allowances plus Corrosion and Erosion Allowances. Threads: Dimension h of ASME B1.20. Machined Surfaces or Grooves: Specified Tolerance (or 0.02" plus Specified Depth of Cut; when tolerance is not specified)</p>

Reprinted from ASME B31.1 – 2012 and ASME B31.3 – 2012 by permission of The American Society of Mechanical Engineers. All rights reserved. No further copies can be made without written permission.

GENERAL TERMS AND CONDITIONS OF SALE OF: BONNEY FORGE (HEREAFTER REFERRED TO AS "BF")

WARRANTY	All products are warranted to be free from manufacturing defects for a period of one (1) year from date of shipment, and any found to be defective within that period will be replaced without charge, provided (1) that the product was used as recommended and in accordance with approved installation and operating practices, (2) that its failure resulted from a manufacturing defect and not from damage due to corrosive, abrasive, or other wear normally to be expected in the services involved, (3) that the product was not modified or changed (unless written approval was given by BF), and (4) that written notice of such defect is delivered to BF during such one (1) year period. No labor costs or other expense or liability is assumed. The Uniform Commercial Code shall not apply to the sale, nor the Michigan statutes adopting the Uniform Commercial Code. This express warranty is in lieu of and excludes all other warranties, guarantees, or representations, expressed or implied. THERE ARE NO IMPLIED WARRANTIES OF MERCHANTABILITY OR OF FITNESS FOR A PARTICULAR PURPOSE.
EXCLUSIONS	Do not use BF products in aircraft or aerospace applications. No warranties, guarantees or representations of any kind are made with respect to such applications. Purchaser assumes all risks of any use in such applications and will indemnify and hold harmless BF against and from any claims, costs (including attorney's fees) and liabilities arising out of such use.
PURCHASER'S REMEDIES	The Purchaser's remedies with respect to any product furnished by BF hereunder that is found not to be in conformity with the terms and conditions of the contract because of breach of contract, breach of express or implied warranty, or negligence shall be limited exclusively to the right of replacement of such defective product or, at our option, repayment of our sale price of the product. In no event shall BF be liable for claims (based upon breach of contract, breach of express or implied warranty, or negligence) for any other damages, whether direct, immediate, foreseeable, consequential, or special or for any expenses incurred by reason of the use or misuse, sale or fabrication of products which do or do not conform to the terms and conditions of the contract.
PRICES	Prices, and other terms of sale and payment, are subject to change without notice. Unless a contrary provision appears in this price schedule, quotation or order acknowledgment, prices may be withdrawn without notice at any time. Stenographic or clerical errors are subject to correction.
ACCEPTANCE OF ORDERS	All orders are subject to BF credit department approval prior to acceptance by BF. No assignment of the Purchaser's rights may be made without the written consent of BF.
REMITTANCES	All accounts are payable in United States funds, free of exchange, collection, or any other charges. If, in the sole discretion of BF, the financial condition of the Purchaser at any time so requires, BF retains the right to require full or partial payment in advance.
PARTIAL SHIPMENTS AND PAYMENTS	BF reserves the right to make partial shipments from time to time, and to render invoices therefore, which shall be due and payable as provided in said invoices and the paragraph entitled "Remittances". If the Purchaser becomes overdue in any such partial payment, BF shall be entitled to suspend work and/or avail itself of other legal remedies.
TAXES	Unless otherwise specifically noted, the amount of any sale, use, occupancy, excise tax, or other tax, of any nature, federal, state, or local for which BF is legally liable, either initially or through failure of payment by Purchaser, shall be added or be in addition to the price quoted and Purchaser agrees to pay the same to BF.
SHORTAGES & DAMAGES IN TRANSIT	Claims for shortages must be made in writing within ten days after receipt of shipment, but loss of or damage to material in transit is the responsibility of the carrier.
DELAYS	All promises of shipment are estimated as closely as possible, and we will use our best efforts to ship within the time promised but do not guarantee to do so, and assume no liability for not doing so. Materials stated to be in stock are subject to prior sale.
CANCELLATION & SUSPENSION	The order or contract is subject to cancellation or instructions to suspend or delay work or delivery only upon receipt of written notification and with our consent, and upon agreement to pay BF's adjustment charge. Orders for special products (usually "price on application" items) may be changed and/or cancelled only upon receipt of written instructions with an expressed agreement to make payment for material used and work already performed.
RETURN OF MATERIAL	No product of our manufacture may be returned without written consent. All goods returned are subject to a handling charge plus freight in both directions and charges for any required reconditioning, unless otherwise specified in writing by BF.
PATENTS	Purchaser will indemnify and hold harmless BF against and from any claims, costs (including attorney's fees) and liabilities arising out of any suit alleging infringement of any patents, by any product supplied by BF under the contract and made in accordance with the design and/or specification furnished by the Purchaser to BF.
GOVERNING LAW	The contract shall be governed by, construed, and enforced in accordance with the laws of the Commonwealth of Pennsylvania, without regard to conflict of law principles.
NO WAIVER	The failure of BF to insist, in any one or more instances upon the performance of any of the terms, covenants, or conditions of the contract or to exercise any right thereunder shall not be construed as a waiver or relinquishment of the future performance of any such term, covenant, or condition or the future exercise of such rights, nor shall it be deemed to be a waiver or relinquishment of any other term, covenant, or condition or the exercise of any other rights under the contract.
DIES, TOOLS AND PATTERNS	Dies, tools and patterns required to produce the article quoted on shall remain the property of BF. Preparation charges for dies, tools and patterns represent only a portion of cost. Payment of such charge does not give you any right, title, or interest in such dies, tools, or other products of preparation. We will not be responsible for retention of dies or patterns on which no orders are received for two years or more.
FORCE MAJEURE	Any delays in or failure of performance of BF shall not constitute default or give rise to any claims or damages if and to the extent that such delay or failure is caused by occurrences beyond the control of BF, including but not limited to acts of God or the public enemy, expropriation or confiscation of facilities, compliance with any order or request of any governmental authority, acts of war, rebellion or sabotage or damage resulting therefrom, embargoes or other export restrictions, fires, floods, explosions, accidents, breakdowns, riots or strikes or other conceived acts of workmen, whether direct or indirect, or any other causes whether or not of the same class or kind as those specifically above named which are not within the control of BF and which by the exercise of reasonable diligence, BF is unable to prevent or provide against.
PURCHASER'S ACCEPTANCE OF ABOVE CONDITIONS	The contract shall be subject to the terms and conditions contained or referred to in BF's price schedule, quotation or order acknowledgment and to no others whatsoever. No waiver, alteration, or modification of the terms and conditions in this price schedule, quotation or order acknowledgment shall be binding unless in writing and signed by an authorized representative of BF.

Note: The material in this catalog is for general information. For specific performance data and proper material selection, consult your Bonney Forge representative. Although every attempt has been made to ensure that the information contained in this catalog is correct, Bonney Forge reserves the right to change designs, materials or specifications without notice.